

ALCOCK ASHDOWN (GUJARAT) LTD.
(A Gujarat Govt. Undertaking)
(SHIP BUILDERS, SHIP REPAIRS, ENGINEERS)
Old Port, Ramsar Works, Bhavnagar 364 001
Tel.: +91 278 2426305, 2427169 Fax: +91 278 2428342
E Mail: purchase@alcockshipyard.com

**TENDER FOR PROCUREMENT OF Cu. Ni. (90:10) FLANGE AND WELDING NECK
FOR YARD NO-258-259 REF. NO- 2011120202**



INDEX

1. **Section 1**: Important dates and information of the tender
2. **Section 2**: General Terms & Conditions
3. **Section 3**: Technical Details
4. **Section 4**: Qualification Criteria
5. **Section 5**: Financial Conditions
6. **Section 6**: Price Bid

SECTION 1: IMPORTANT DATES AND INFORMATION OF THE TENDER

Title of the Tender : Tender for Procurement of Cu. Ni.(90:10) Flange and Welding Neck for Yard No-258-259 Ref. No- 2011120202

Tender Number : AAGL/PUR/Y: 258-259/Cu. Ni.(90:10) Flange and Welding Neck/ Ref. 2011120202/DT: 07.02.2012

Last date of Submission : 5:00 PM on 16th Feb., 2012.

Mode of Submission : Speed Post/Register Post/Courier/Hand Delivery

Technical bid Opening : 11:00 AM on 17th Feb., 2012.

Technical bid Evaluation : Technical bids so received will be evaluated by the AAGL technical staff. Decision for technically qualifying any offer lies with AAGL.

Price bid Opening : Price bids of only technically qualified bidders will be opened after technical scrutiny.

Delivery Time : 10 Days

Validity : 60 Days

Important Note : Envelop should be superscripted as below.
"Tender for Procurement of Cu. Ni.(90:10) FLANGE AND WELDING NECK For Yard No-258-259 Ref. No- 2011120202"

SECTION 2: GENERAL TERMS & CONDITIONS

- a. Interested parties may obtain the tender document from the official website. www.alcockshipyard.com free of cost.

The duly filled Tender Document is to be sent to:

The Managing Director
Alcock Ashdown (Guj) Ltd.
Ramsar Works, Old Port
Bhavnagar 364 001
Gujarat (India)

- b. The tender document can be obtained from the office of AAGL during office hrs i.e. 9:00 AM to 5:00 PM up to the last date mentioned in Section 1.
- c. The bids should be submitted in a sealed cover containing following two envelopes:

Technical bid:

1. Technical qualification page along with all the documents mentioned in it.
2. Copy of the Section 2 to section 6 including blank pages of price bid duly signed and stamped on all the pages.

Price bid: Containing the price bid in the form provided in the tender document. No condition other than what already mentioned in the tender documents will be accepted.

- d. Price bid of only technically qualified bidders will be opened.
- e. Technical qualification itself will consist of two parts. One dealing with the technical qualification of the firm and second dealing with the equipment/ material. Price bid of only technically qualified bids shall be considered.
- f. The technical bid and price bid should be submitted in two separate sealed envelopes. The technical bid envelope and the price bid envelope should have "Technical Bid" and "Price bid" clearly written respectively on them. These two envelopes should then be put in third envelope and submitted to AAGL after proper sealing.
- g. The bid shall be submitted through speed post/ register post/ courier or hand delivery. The complete liability to ensure that the bid shall reach AAGL in time will be with the bidder. AAGL, under no circumstance will allow any allowance for the delay arising out of postal or courier delivery. No bidder will have any right whatsoever for his bid if it is not obtained in time and in proper format.
- h. AAGL reserves the right to accept or reject any or all tenders in part or full or to cancel the issue of tender documents without assigning any reason whatsoever. Similarly, in the interest of company, AAGL has absolute right to go for retendering without assigning any reason whatsoever to anyone.
- i. Bidder has to accept all terms and conditions unconditionally.
- j. Negotiations, if any, will be held only with L1 bidder.
- k. AAGL will provide clarifications etc. to any bidder but it is being made clear that any

clarification etc. is not legally binding on AAGL unless it becomes part of the tender document. So these clarifications should be treated as only clarifications of the existing clauses rather than any concession or relaxation. If any important modifications/ rewording etc. are needed then the document itself will be changed and reposted on the site.

- l. Management reserves the right to modify the tender document for more clarity and/or to get more competition. If there is any revision in the tender document, the same will be published on our website www.alcockshipyard.com. No paper advertisement or individual communication will be done with any bidder in this regard. All the interested parties are requested to kindly visit this website regularly for any updates. The bidders may also get automatic notifications of new tenders as well as any modifications if they register themselves with the website.
- m. Kindly note that all tender notices are posted on our website only. Usually no advertisements of these tenders are published in news papers. You can receive the tender notification automatically by registering your e-mail id on our website.
- n. No EMD amount or tender fees has been kept for this tender. But if any bidder backs out after receiving LOI or Purchase Order from AAGL a penalty of 5% of the amount may be imposed and same may be deducted from the payments pending with AAGL. In case no payment is pending then the bidder will be blacklisted and will be allowed to bid in future only after paying the penalty amount.

SECTION 3: TECHNICAL DETAILS

Sr. No.	Item	Technical Specification	Qty. (Nos.)	To be declared / confirmed by Supplier in Yes or No
1.	Cu. Ni (90:10) FLANGE	<u>Standard:</u> BS 4504 PN10 <u>Size:</u> 80mmNB <u>Approval / Classification:</u> Manufacturer's Test Certificate is require with Supply <u>Note:</u> Flange not to have raised face	30 Nos.	
2.	Cu. Ni. (90:10) WELDING NECK	<u>Size:</u> 80mmNB <u>Approval / Classification:</u> Manufacturer's Test Certificate is require with Supply	30 Nos.	

- **As per Drawing enclosed with this tender document.**

SECTION 4: QUALIFICATION CRITERIA

No	Description	Required	To be declared / confirmed by Bidder in Yes or No
1	The bidder should have supplied same material to any industry / shipyard / other institution.	Copy of work order / purchase order for similar work/supply carried out in any industry / shipyard / other institution.	
2	Acceptance of all the conditions fully and unconditionally	Copy of all the sections including blank pages of price bid duly signed and stamped on all the pages.	
3	Delivery Time as per Section – 1	Agreed or not?	

SECTION 5: FINANCIAL CONDITIONS

1. Price :

Price to be quoted by the bidder should be fixed and should cover the entire scope of this supply. The price quoted by the bidder to be exclusive of all taxes, levies, duties etc. as may be applicable.

2. Penalty:

Delay in supply beyond agreed period will attract penalty of 0.5% per week and Max. 5% of total order value.

3. Payment:

The payment will become due on AAGL once the bills are completely certified. AAGL will make the payment within 45 days.

4. Guarantee:

Material used / workmanship of supplied item will be guaranteed for twelve months from the date of delivery of the respective vessels to Indian Navy at bidder's cost. Any defect occurred on account of inferior quality of material used / poor workmanship shall be attended by the bidder during guarantee period, at the place where the vessel is available for repairs.

5. Validity:

Validity of your quotation must be for 60 Days from tender opening date.

SECTION 6: PRICE BID

Sr. No.	Item	Technical Specification	Qty. (Nos.)	Price Per Unit Rs.	Total Price Rs.
1.	Cu. Ni (90:10) FLANGE	As per Section : 3	30 Nos.		
2.	Cu. Ni. (90:10) WELDING NECK	As per Section : 3	30 Nos.		

Note:

- The bidder has to indicate all other charges, taxes, duties, transportation etc while quoting rates and provide F.O.R. yard base price.

P & F	%
Excise Duty	%
CST	%
VAT	%
Insurance &Transportation	%
Commissioning	%
Service Tax	%
Other	%
Contact Person : Name:	
Mo. No :	Email :

- The complete supply shall be subject to AAGL / WOT (B) inspection. Any recommendation given by said authorities for material / workmanship shall be made good by the bidder without any extra cost to AAGL.
- AAGL has full right to derive a formula to bring all the bidders to a common denominator so as to compare the offers.
- AAGL reserves the right to determine the L1 party for item.
- The price is inclusive of all expenses incurred for the technical support during the installation and commissioning including the transportation/accommodation charges of the personnel involved viz. installation support, commissioning support, training and documentation etc.
- The offer is being made after reading and accepting all the conditions fully and unconditionally.
- If the bidder backs out after making the offer then AAGL will have right to impose a penalty of 5% of the amount and the same will be deducted from the pending payments of the bidder. If no payment is pending then the bidder will stand blacklisted and will be allowed to bid in AAGL only after he deposits the penalty money.

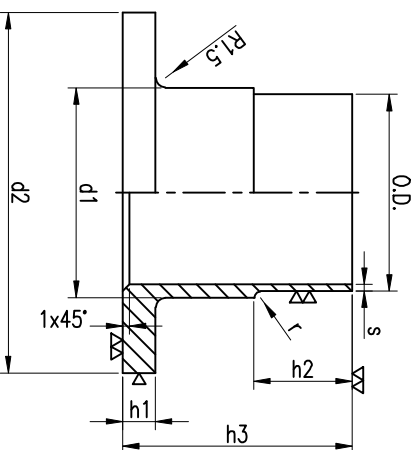

WELDING NECK

DIMENSION TABLE (ALL DIMENSIONS ARE IN MM)										
SER. NO.	SIZE NB.	O.D.	S	d1	d2	h1	h2	h3	r	REMARKS
1	80	89	2	91	138	7	15	50	3	

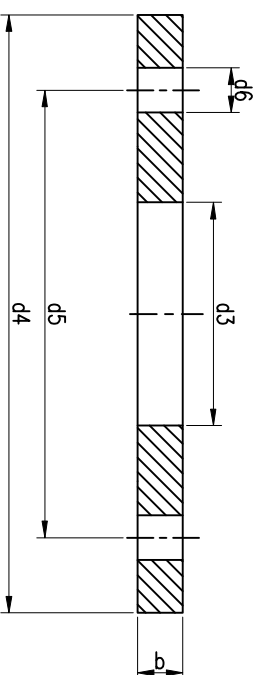

OUTER FLANGE

DIMENSION TABLE (ALL DIMENSIONS ARE IN MM)									
SER. NO.	SIZE NB.	d3	d4	d5	d6	b	NO.OF BOLTS	BOLT SIZE	REMARKS
1	80	94	200	160	18	18	8	f ⁿ	